

KNM Series

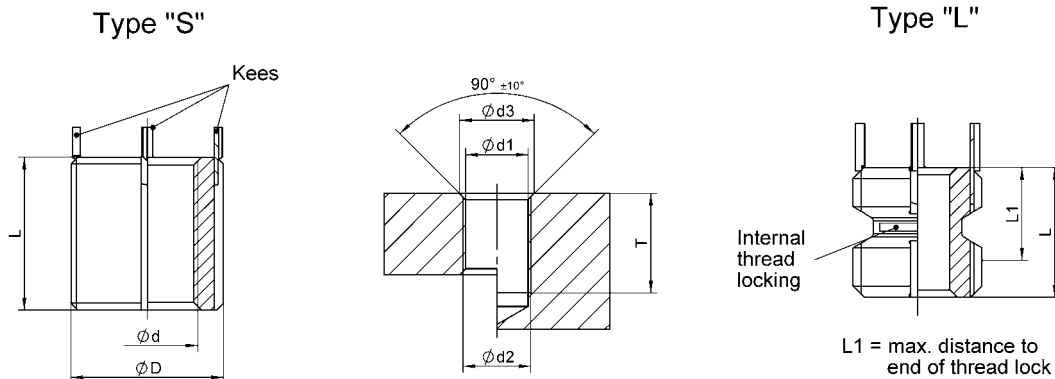

Kees:
Inserts with internal thread size of M6 and under are furnished with 2 locking kees.
Inserts with internal thread of M8 and above are furnished with 4 locking kees.

Part-no.		Dimensions				
Standard type "S"	Locking type "L"	Ø d 5H	Ø D 4h	Shear engagement mm ²	L ± 0,30	L1
KNM5X0,8		M5X0,8	M8X1,25	104,9	8	7,6
	KNML5X0,8			83,1		
KNM6X1,0		M6X1,0	M10X1,25	177,7	10	8,2
	KNML6X1,0			152,7		
KNM8X1,25		M8X1,25	M12X1,25	266,7	12	9,5
	KNML8X1,25			242,7		
KNM10X1,5		M10X1,5	M14X1,5	341,6	14	10,0
	KNML10X1,5			316,4		
KNM12X1,75		M12X1,75	M16X1,5	470,2	16	11,2
	KNML12X1,75			441,4		

Part-no.	Installation dimensions					Removal dimensions	
	d1 Tap drill Ø	d3 Counter-sink Ø	Thread		Hand installation tool part-no.	Drill	
			Ø d2 6H	T min.		Ø	Depth
KNM5X0,8	6,90 +0,100 -0,025	8,25	M8X1,25	9,5	KRTM5-01	5,5	4,00
KNML5X0,8							
KNM6X1,0	8,80 +0,100 -0,025	10,25	M10X1,25	11,5	KRTM6-01	7,5	4,75
KNML6X1,0							
KNM8X1,25	10,80 +0,100 -0,025	12,25	M12X1,25	13,5	KRTM8-01	9,5	4,75
KNML8X1,25							
KNM10X1,5	12,80 +0,130 -0,025	14,25	M14X1,5	15,5	KRTM10-01	11,5	4,75
KNML10X1,5							
KNM12X1,75	14,75 +0,130 -0,025	16,25	M16X1,5	17,5	KRTM12-01	13,5	4,75
KNML12X1,75							